

CediFER
 -SAE 4140
 -TEMPERAR E REVENIR :
 44-46HrC
 -OXIDAR PRETO

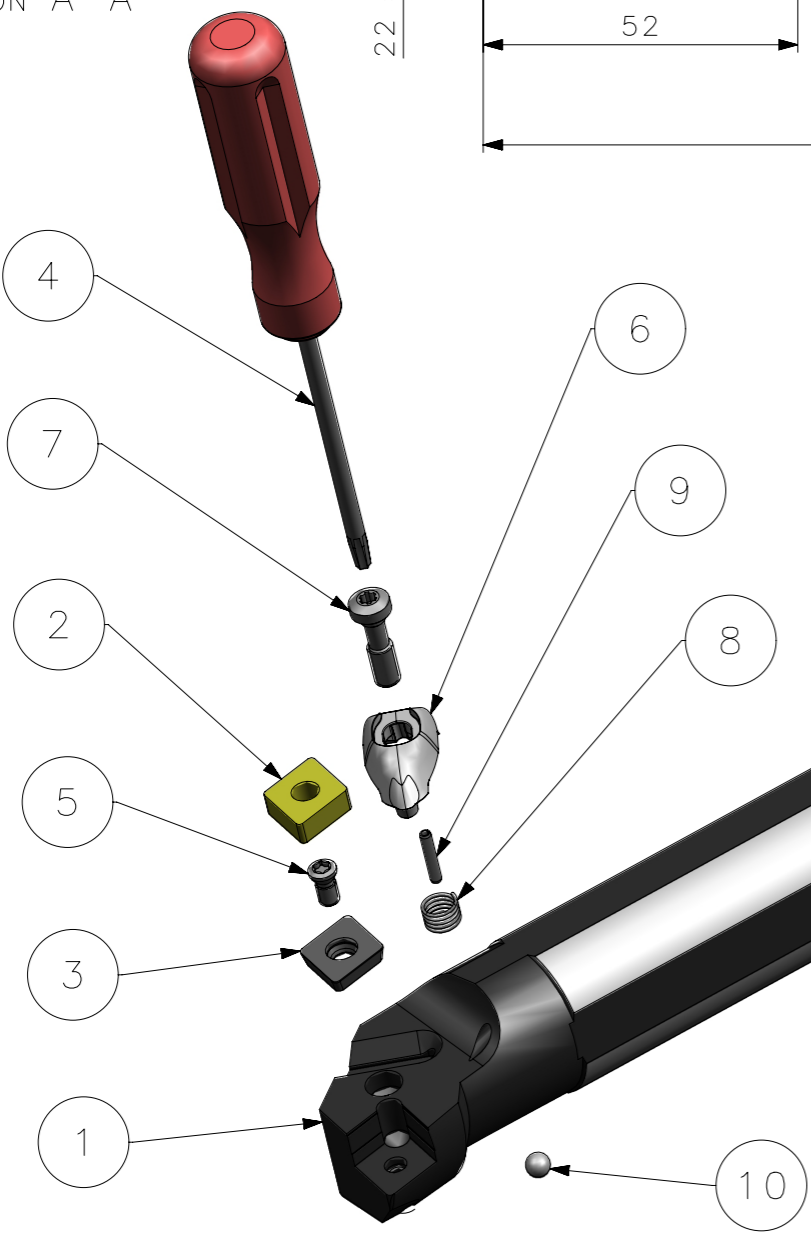
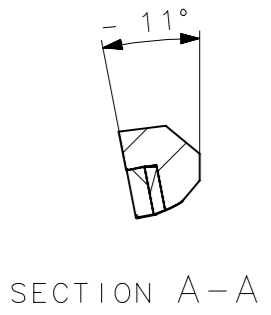
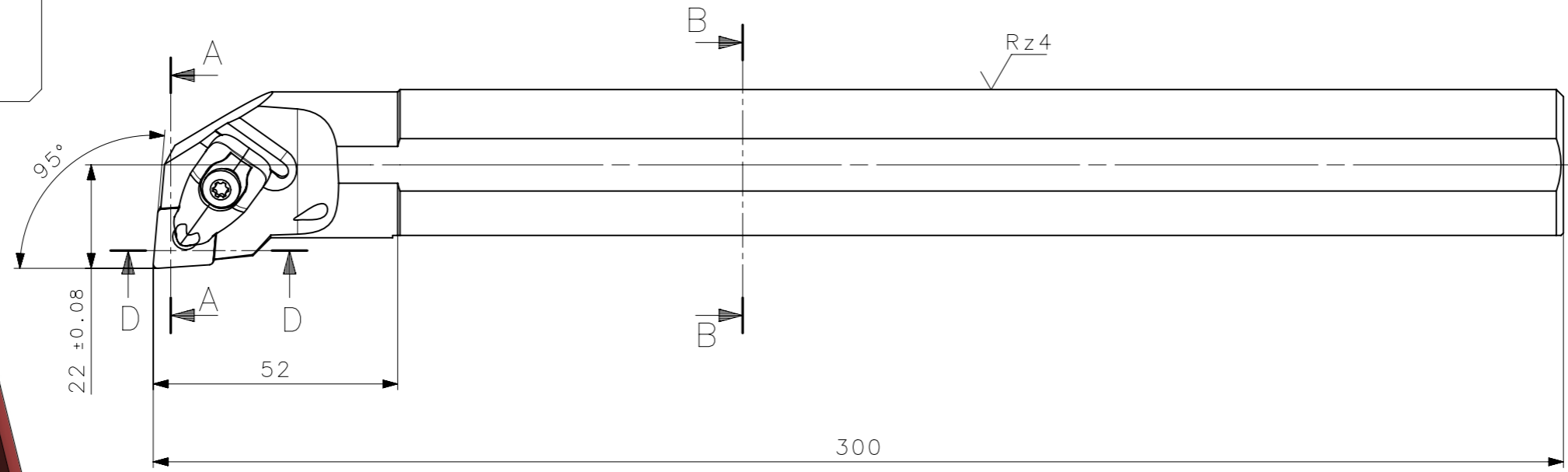
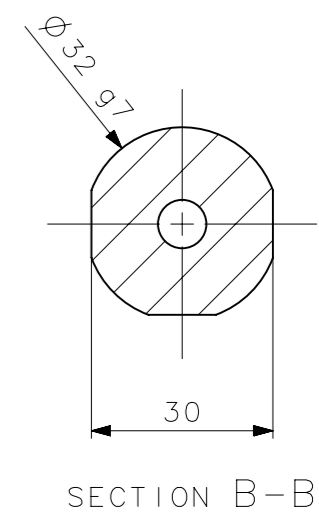
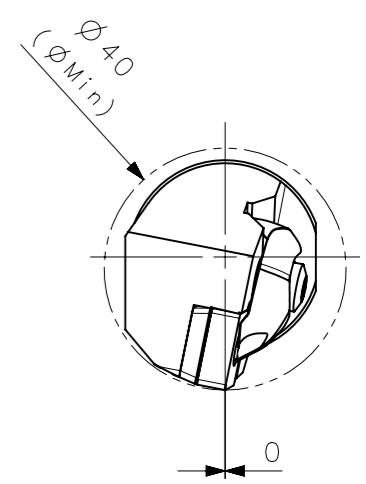
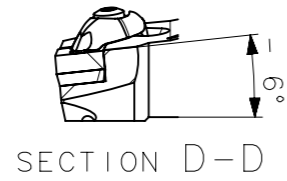

MASSA = 1.64 kg

Item	Quant.	Descricao	Material	Obs
10	01	ESFERA_3_16_A32T_A32T_DCLNR12	HARD TOOLS	
9	01	PINO_3113030307_A32T_DCLNR12	HARD TOOLS	
8	01	MOLA_556100158_A32T_DCLNR12	HARD TOOLS	
7	01	PARAF_GRAMPO_551208602_A32T_DCLNR12	HARD TOOLS	
6	01	GRAMPO_541202802_A32T_DCLNR12	HARD TOOLS	
5	01	PARAF_CALCO_551302002_A32T_DCLNR12	HARD TOOLS	
4	01	CHAVE_TORX_T15F_A32T_DCLNR12	HARD TOOLS	
3	01	CALCO_532223603_A32T_DCLNR12	W WELLER	
2	01	INSERTO_CNMG120408_A32T_DCLNR12	W WELLER	
1	01	CORPO	SAE 4140	

ACABAMENTO DE SUPERFÍCIES	
DIN 1302	DIN 3141
Rz1	
Rz4	
Rz16	
Rz63	
M.Bruto	

Obs: Quebrar cantos vivos
 Ref. do cliente(Produto):
 Ref. do cliente(ferramenta):
 Substitui:
 Cliente:

CediFER ABNT NB-8
 Desenhado: 04/02/10 MARCOS
 Verificado: 04/02/10 PEDRO
 Aprovado: 04/02/10 RENATO
 Escala: 1:1
 Folha: 1 - 3
 Titulo: BARRA DE MANDRILAR STD. (DESENHO DO CONJUNTO)
 Des. N.: D_A32T_DCLNR12
 Formato: A3

A3



SÍMBOLOS GEOMÉTRICOS					