

CediFER
 -SAE 4140
 -TEMPERAR E REVENIR :
 44-46HrC
 -OXIDAR PRETO

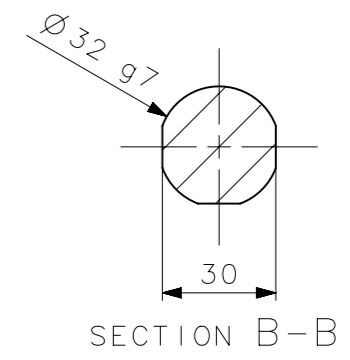

TOLERANCIA ANGULAR ±1°
 COTAS SEM INDICAÇÃO DE TOLERANCIA,
 SEGUIR CONFORME TABELA **DIN 7168-f**
 INDICADA NO FORMATO.

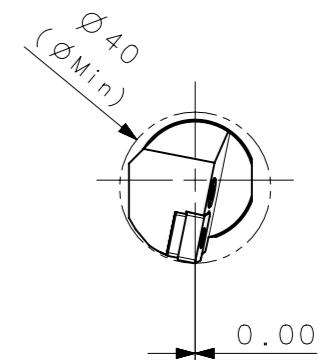
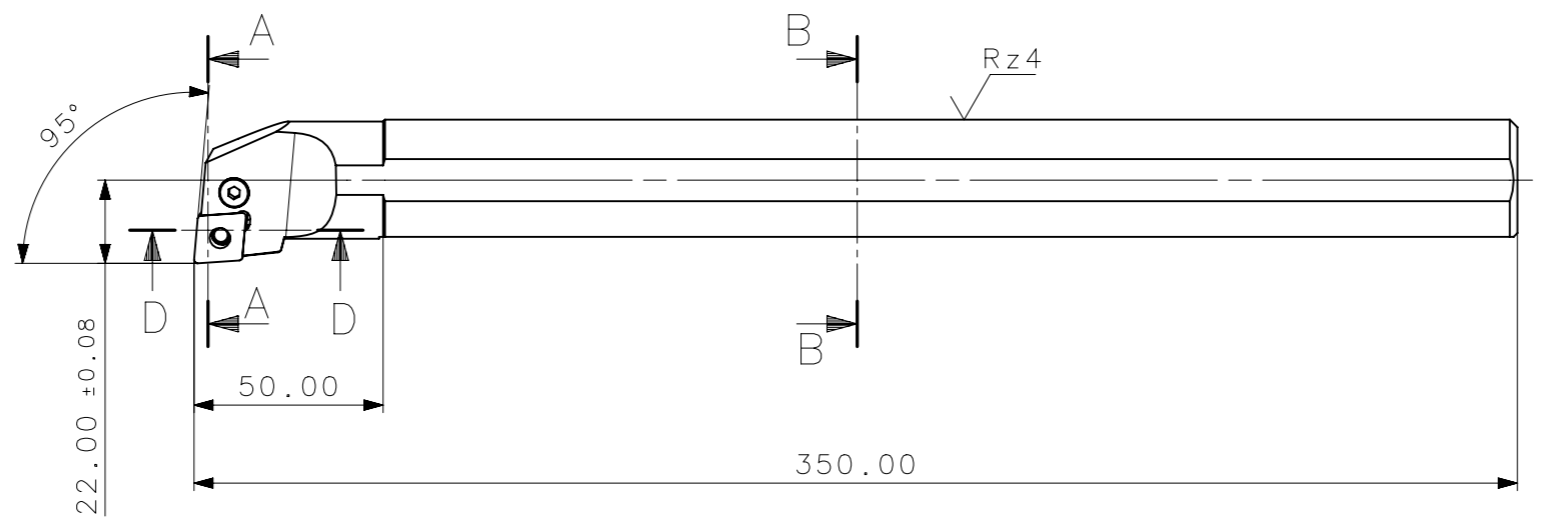
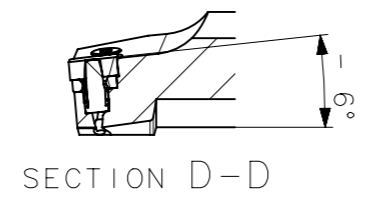

MASSA=2.05kg

7	01	REBITE_1743861_S32U_PCLNR12	HARD TOOLS	
6	01	PARAF_ALAVANCA_1743858_S32U_PCLNR12	HARD TOOLS	
5	01	CALCO_17131850M_S32U_PCLNR12	HARD TOOLS	
4	01	CHAVE_ALLEN_3MM_S32U_PCLNR12	HARD TOOLS	
3	01	ALAVANCA_1743848M_S32U_PCLNR12	HARD TOOLS	
2	01	INSERTO_CNMG120408_S32U_PCLNR12	W WELLER	
1	01	CORPO	SAE 4140	

ACABAMENTO DE SUPERFÍCIES		Item		Quant.	Descricao	Material	Obs
DIN 1302	DIN 3141	Obs:Quebrar cantos vivos					
		Ref. do cliente(Produto):					
		Ref. do cliente(ferramenta):			Substitui:		Cliente :
				ABNT NB-8 Escala: 1:1	Data: 10/11/08 Verificado: 10/11/08 Aprovado: 10/11/08	Nome: MARCOS PEDRO RENATO Folha: 1 - 3	Titulo : BARRA DE MANDRILAR STD. (DESENHO DO CONJUNTO) Des. N. : D_S32U_PCLNR12
						Formato: A3	

			SÍMBOLOS GEOMÉTRICOS				