

CediFER
 -SAE 4140
 -TEMPERAR E REVENIR :
 44-46HrC
 -OXIDAR PRETO

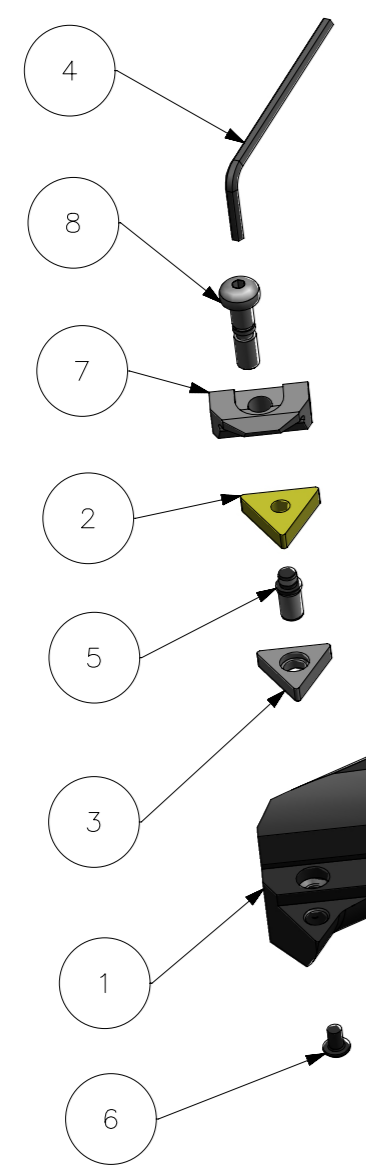
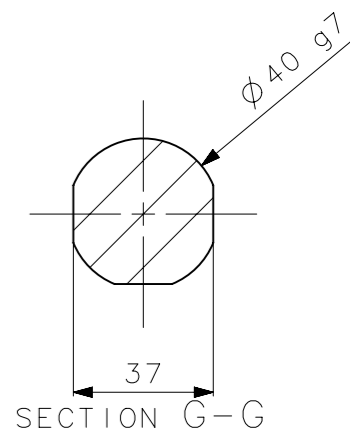
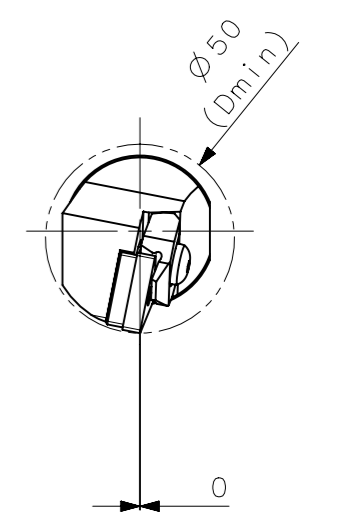
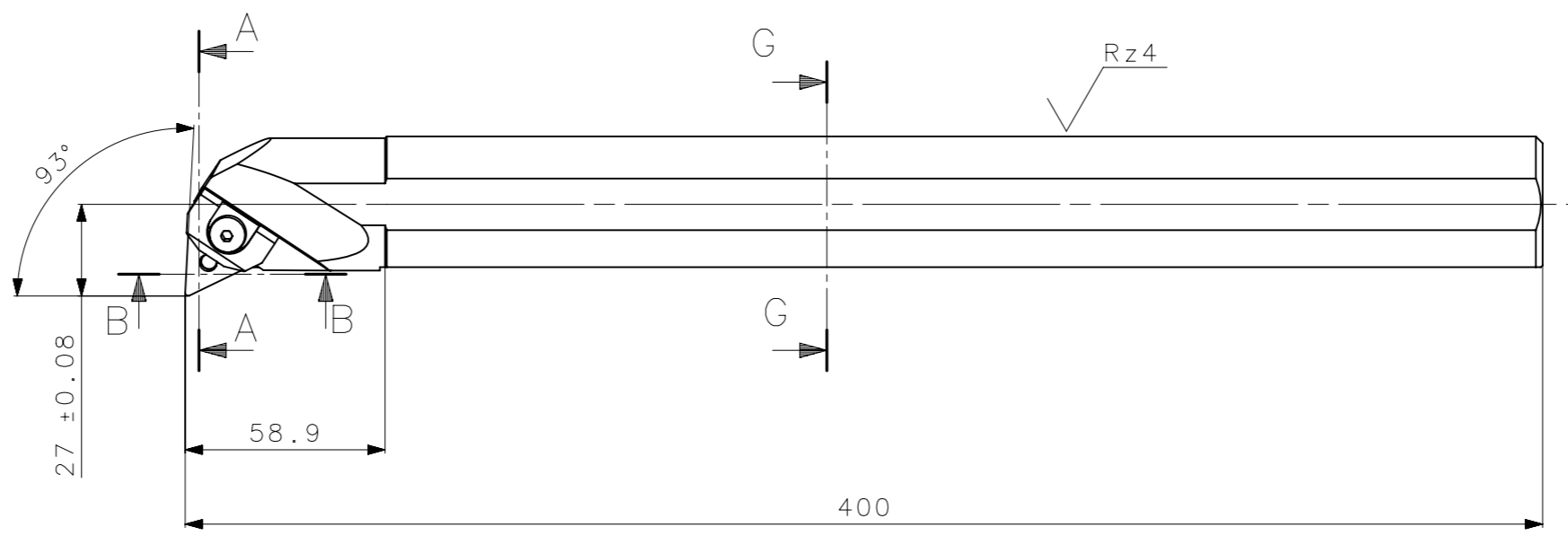
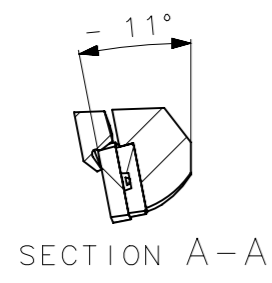
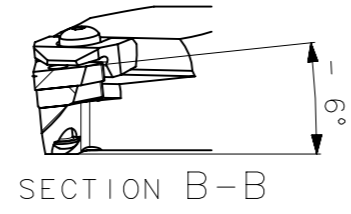

MASSA=3.63kg

Item	Quant.	Descricao	Material	Obs
8	1	PARAF_GRAMPO_17038821_S40V_PTFNR22W	HARD TOOLS	
7	1	GRAMPO_17038821_S40V_PTFNR22W	HARD TOOLS	
6	1	PARAF_PINO_551203002_S40V_PTFNR22W	HARD TOOLS	
5	1	PINO_531302103_S40V_PTFNR22W	HARD TOOLS	
4	1	CHAVE_ALLEN_3MM_S40V_PTFNR22W	HARD TOOLS	
3	1	CALCO_1703855_S40V_PTFNR22W	W WELLER	
2	1	INSERTO_TNMG220408_S40V_PTFNR22W	W WELLER	
1	1	CORPO	SAE 4140	

ACABAMENTO DE SUPERFICIES	ABNT NB-8	DIN 1302	DIN 3141
Rz1			
Rz4			
Rz16			
Rz63			
M.Bruto			

Obs: Quebrar cantos vivos
 Ref. do cliente (Produto):
 Ref. do cliente (ferramenta):
 Substitui:
 Cliente:

CediFER
 ABNT NB-8
 Desenhado: 21/08/09 MARCOS
 Verificado: 21/08/09 PEDRO
 Aprovado: 21/08/09 RENATO
 Escala: 1:1
 Folha: 1 - 3
 Titulo: BARRA DE MANDRILAR STD. (DESENHO DO CONJUNTO)
 Des. N.: D_S40V_PTFNR22W
 Formato: A3

A3



SÍMBOLOS GEOMÉTRICOS	
	Posição Real
	Concentricidade
	Simetria
	Paralelismo
	Perpendicularidade
	Angularidade
	Cilindricidade
	Planicidade
	Circularidade
	Retilnearidade
	Perfil de Superfície
	Perfil de Uma Linha
	Batimento
	Batimento Total