

RevNo	Revisao - Era	Data	Proj.	Aprov.

CediFER
 -SAE 4140
 -TEMPERAR E REVENIR :
 44-46HrC
 -OXIDAR PRETO

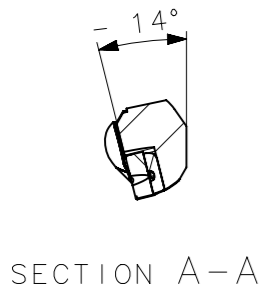

A3

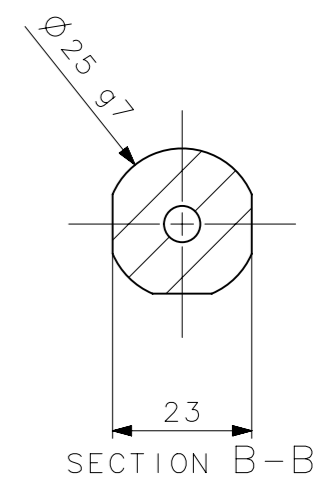
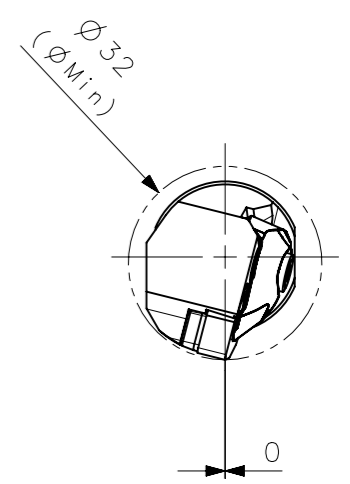
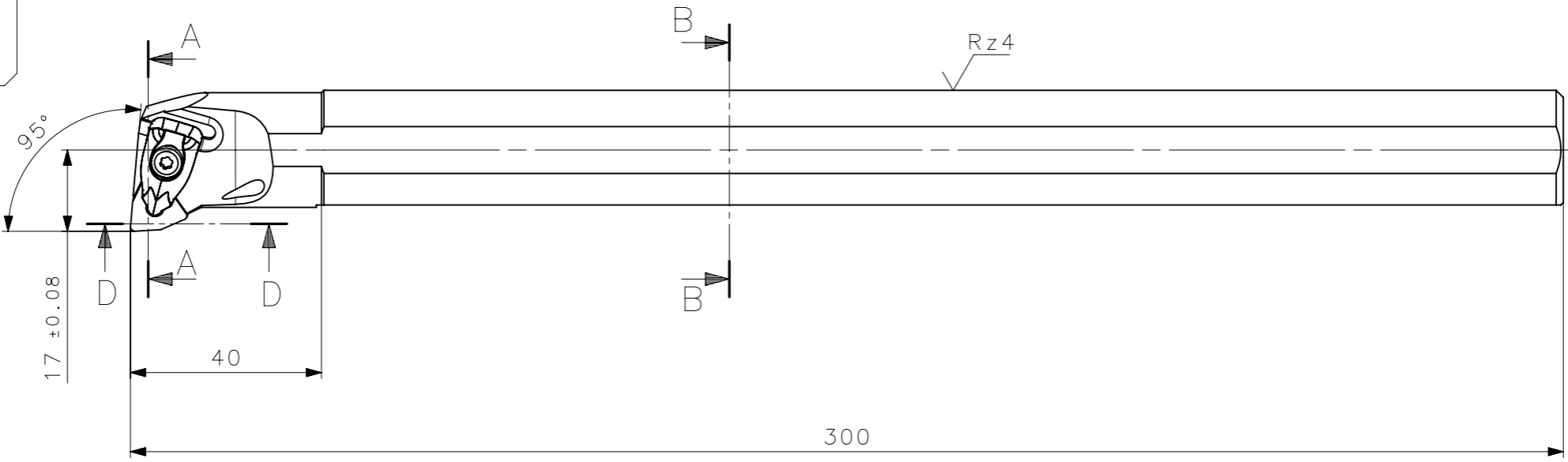
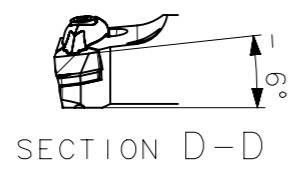
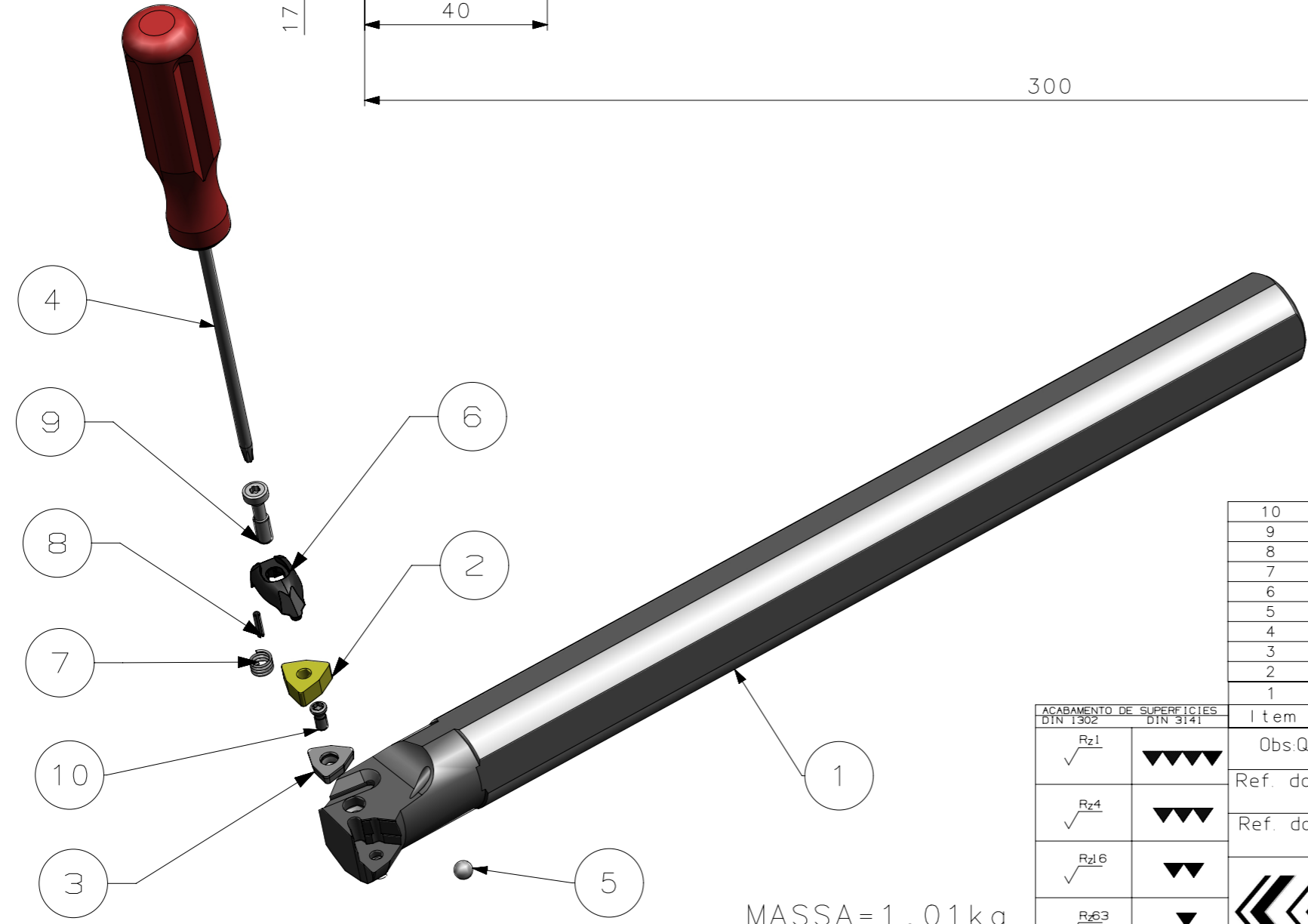

MASSA=1.01kg

10	01	PARAF_DO_CALC_551302004_A25T_DWLNRO6	HARD TOOLS	
9	01	PARAF_GRAMPO_551208601_A25T_DWLNRO6	HARD TOOLS	
8	01	PINO_3113030255_A25T_DWLNRO6	HARD TOOLS	
7	01	MOLA_556100157_A25T_DWLNRO6	HARD TOOLS	
6	01	GRAMPO_541202801_A25T_DWLNRO6	HARD TOOLS	
5	01	ESFERA_3_16_A25T_DWLNRO6	STD.	
4	01	CHAVE_TORX_T9F_A25T_DWLNRO6	HARD TOOLS	
3	01	CALCO_532232801_A25T_DWLNRO6	W WELLER	
2	01	INSERTO_WNMG060408_A25T_DWLNRO6	W WELLER	
1	01	CORPO	SAE 4140	

ACABAMENTO DE SUPERFÍCIES	
DIN 1302	DIN 3141
$\sqrt{Rz1}$	
$\sqrt{Rz4}$	
$\sqrt{Rz16}$	
$\sqrt{Rz63}$	
$\sqrt{M.Bruto}$	

Obs: Quebrar cantos vivos
 Ref. do cliente(Produto):
 Ref. do cliente(ferramenta):
 Substitui:
 Cliente:

CediFER Logo

ABNT NB-8

Desenhado: 04/02/10 MARCOS
 Verificado: 04/02/10 PEDRO
 Aprovado: 04/02/10 RENATO

Data: Nome: Titulo :
 Escala: 1:1 Folha: 1 - 3
 BARRA DE MANDRILAR STD.
 (DESENHO DO CONJUNTO)

Des. N. : D_A25T_DWLNRO6
 Formato: A3
