

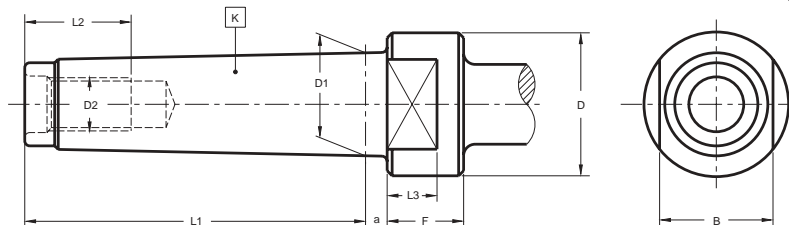

MORSE & QUICK CHANGE SYSTEM
MORSE & SISTEMA CAMBIO RÁPIDO

7

DIN 228 form A - DIN 2207
DIN 228 forma A - DIN 2207



K	L ₁	L ₂	L ₃	D	D ₁	D ₂	F min	B d9	a
MORSE 1	53,5	16	—	—	12,065	M-6	—	—	3,5
MORSE 2	64	24	—	—	17,780	M-10	—	—	5
MORSE 3	81	24	12	36	23,825	M-12	18	24	5
MORSE 4	102,5	32	15	43	31,267	M-16	23	32	6,5
MORSE 5	129,5	40	18	60	44,399	M-20	28	45	6,5
MORSE 6	182	47	25	84	63,348	M-24	39	65	8

DIN 228 form B - DIN 1806
DIN 228 forma B - DIN 1806

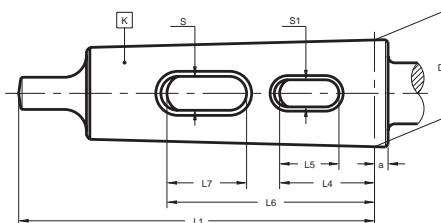



K	L ₁	L ₄	L ₅	L ₆	L ₇	D ₁	S	S ₁	a
MORSE 1	62	—	—	—	—	12,065	—	—	3,5
MORSE 2	75	—	—	—	—	17,780	—	—	5
MORSE 3	94	55,5	32	—	—	23,825	—	8,3	5
MORSE 4	117,5	59,5	37	—	—	31,267	—	8,3	6,5
MORSE 5	149,5	64	42	—	—	44,399	—	12,4	6,5
MORSE 6	210	56	35	122	47	63,348	19,5	16,4	8
METRICO 80	220	64	43	136	54	80	26,5	19,5	8

Material: Case-hardening alloy steel. Case-hardened and tempered. Minimum strength in core 880 N/mm². Surface hardness Rc 57 ÷ 60.
Taper tolerance: Grade AT4.
Material: Acero aleado de cementación. Cementado y templado. Resistencia mínima en el núcleo 880 N/mm². Dureza superficial Rc 57 ÷ 60.
Tolerancia de conicidad: Calidad AT4.



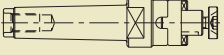

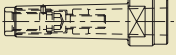
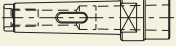
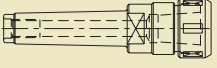
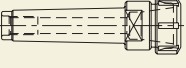
01

MORSE TAPER WITH THREAD CONO MORSE CON ROSCA

DESCRIPTION DENOMINACION	Page Pag.
UNIVERSAL ARBORS PORTAFRESAS COMBINADO 	7/4
REDUCING ADAPTERS For tanged Morse taper tools DIN 228-B or Morse <i>taper tools with thread DIN 228-A</i> REDUCTORES PASANTES A MORSE Para herramientas con lengüeta o rosca 	7/6
REDUCING ADAPTERS With double effect pull stud For Morse taper tools with thread <i>DIN 228-A</i> REDUCTORES MORSE A MORSE Para herramientas con rosca 	7/6
EXTENSIONS AND REDUCING ADAPTERS For tanged Morse taper tools DIN 228-B REDUCTORES Y PROLONGADORES MORSE A MORSE Para herramientas con lengüeta 	7/7
COLLET CHUCKS FOR DIN 6388 COLLETS PORTAPINZAS DIN 6388 	7/9
COLLET CHUCKS ER TYPE (DIN 6499) PORTAPINZAS DIN 6499 (TIPO ER) 	7/10

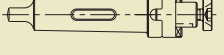
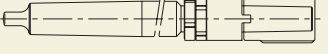
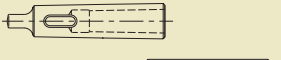
02

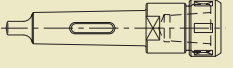
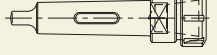
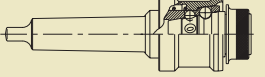
MORSE TAPER WITH TANG CONO MORSE CON LENGÜETA

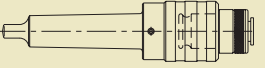
DESCRIPTION DENOMINACION	Page Pag.
UNIVERSAL ARBORS PORTAFRESAS COMBINADO 	7/4
SHELL REAMER ARBORS EJE PORTAESCARIADOR 	7/5
EXTENSIONS AND REDUCING ADAPTERS For tanged Morse taper tools <i>DIN 228-B</i> REDUCTORES Y PROLONGADORES MORSE A MORSE Para herramientas con lengüeta 	7/7
BASIC ADAPTERS FOR MODULAR TOOLING ADAPTADORES PARA UTILLAJE MODULAR 	7/8
COLLET CHUCKS FOR DIN 6388 COLLETS PORTAPINZAS DIN 6388 	7/9
COLLET CHUCKS ER TYPE (DIN 6499) PORTAPINZAS DIN 6499 (TIPO ER) 	7/10
QUICK-CHANGE HOLDER PORTABROCAS DE CAMBIO RÁPIDO 	7/12 7/13 7/14
QUICK-CHANGE ADAPTERS ADAPTADORES PARA PORTABROCAS DE CAMBIO RÁPIDO 	7/15 ...21
QUICK-CHANGE TAPPING CHUCKS Doble axial compensation PORTAMACHOS DE CAMBIO RÁPIDO. Tipo BILZ 	7/11

TYPE TIPO	TOOL Ø HERRAMIENTA	LENGTH LONGITUD
M2, M3, M4, M5	13 - 50	M

For milling cutters with longitudinal or tenon drive DIN 138
Para fresas con chavetero longitudinal o transversal DIN 138

Alternative solutions Soluciones alternativas 003 02 54 + 001 54 0 ³/₅ pgs. 7/8 and 9/3

Fig.1

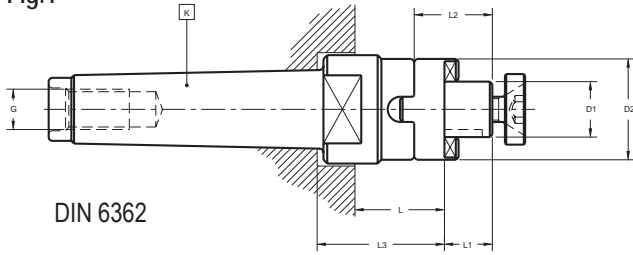

DIN 6362

Fig.2

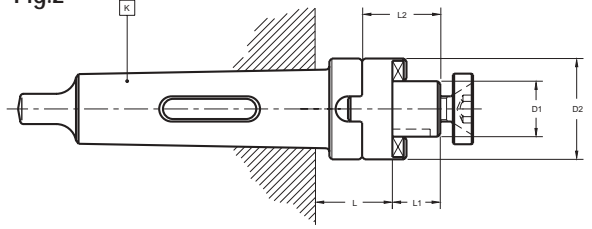

Maximum circular deviation between K and D₁ ≤ 0,008
Desviación circular máxima entre K y D₁ ≤ 0,008

FIG.	K	D ₁	LENGHT - LONGITUD		L ₁	L ₂	L ₃	D ₂	G	COD.
			L							
1	M2	13	—		12	22	43	28	M-10	001 01 02 03 20
1	M2	16	—		17	27	43	32	M-10	001 01 02 03 30
1	M2	22	—		19	31	43	40	M-10	001 01 02 03 40
1	M3	16	36		17	27	48	32	M-12	001 01 02 04 30
1	M3	22	36		19	31	48	40	M-12	001 01 02 04 40
1	M3	27	36		21	33	48	48	M-12	001 01 02 04 50
1	M3	32	36		24	38	48	58	M-12	001 01 02 04 60
1	M4	16	40		17	27	55	32	M-16	001 01 02 05 30
1	M4	22	40		19	31	55	40	M-16	001 01 02 05 40
1	M4	27	40		21	33	55	48	M-16	001 01 02 05 50
1	M4	32	55		24	38	70	58	M-16	001 01 02 05 60
1	M4	40	55		27	41	70	70	M-16	001 01 02 05 70
1	M5	16	55		17	27	73	32	M-20	001 01 02 06 30
1	M5	22	55		19	31	73	40	M-20	001 01 02 06 40
1	M5	27	55		21	33	73	48	M-20	001 01 02 06 50
1	M5	32	55		24	38	73	58	M-20	001 01 02 06 60
1	M5	40	55		27	41	73	70	M-20	001 01 02 06 70
1	M5	50	55		30	46	73	90	M-20	001 01 02 06 80
2	M3	27	30		21	33		48		001 02 02 04 50
2	M3	32	30		24	38		58		001 02 02 04 60
2	M5	40	46		27	41		70		001 02 02 06 70
2	M5	50	46		30	46		90		001 02 02 06 80

Accessories, see pages 16/3 - 16/11
Accesorios ver págs. 16/3 - 16/11

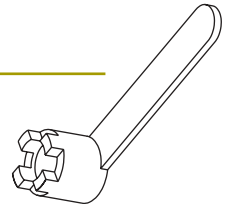
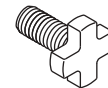
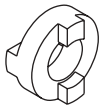

D₁

13	001 99 02 01 20	001 99 01 22 20	001 99 01 12 20
16	001 99 02 01 30	001 99 01 22 30	001 99 01 12 30
22	001 99 02 01 40	001 99 01 22 40	001 99 01 12 40
27	001 99 02 01 50	001 99 01 22 50	001 99 01 12 50
32	001 99 02 01 60	001 99 01 22 60	001 99 01 12 60
40	001 99 02 01 70	001 99 01 22 70	001 99 01 12 70
50	001 99 02 01 80	001 99 01 22 80	001 99 01 12 80

OPTIONS - OPCIONALES



001 99 03 02 20	001 99 01 01 20	001 99 04 01 20
001 99 03 02 30	001 99 01 01 30	001 99 04 01 30
001 99 03 02 40	001 99 01 01 40	001 99 04 01 40
001 99 03 02 50	001 99 01 01 50	001 99 04 01 50
001 99 03 02 60	001 99 01 01 60	001 99 04 01 60
001 99 03 02 70	001 99 01 01 70	001 99 04 01 70
001 99 03 02 80	001 99 01 01 80	001 99 04 01 80

TYPE TIPO	TOOL Ø HERRAMIENTA	LENGTH LONGITUD
M4, M5	19 - 32	M

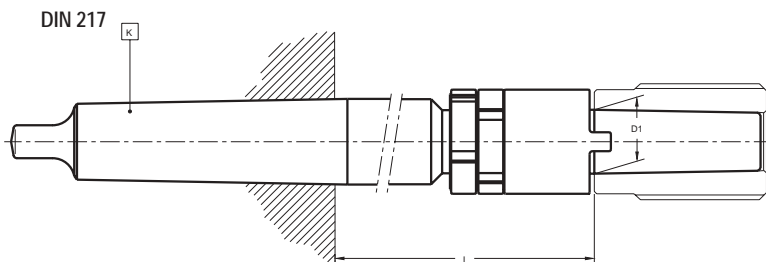
Alternative solutions
Soluciones alternativas 003 02 54 + 001 54 51 pgs. 7/8 and 9/5



Maximum circular deviation between K and $D_1 \leq 0,008$
Desviación circular máxima entre K y $D_1 \leq 0,008$

K	D_1	LENGHT - LONGITUD L	COD.			
M4	19	124	001 02 51 05 99	001 99 12 01 30	001 99 11 01 99	001 99 13 01 99
M4	22	131	001 02 51 05 40	001 99 12 01 40	001 99 11 01 40	001 99 13 01 40
M4	27	138	001 02 51 05 50	001 99 12 01 40	001 99 11 01 50	001 99 13 01 50
M5	27	138	001 02 51 06 50	001 99 12 01 40	001 99 11 01 50	001 99 13 01 50
M5	32	146	001 02 51 06 60	001 99 12 01 60	001 99 11 01 60	001 99 13 01 60

TYPE TIPO	TYPE TIPO	LENGTH LONGITUD
M3, M4, M5	M1 - M4	M

With double effect pull stud. For tanged Morse taper tools DIN 228-B or Morse taper tools with thread DIN 228-A
Con tirante de doble efecto. Para herramientas con lengüeta DIN 228-B o rosca de tiro DIN 228-A

Fig.1

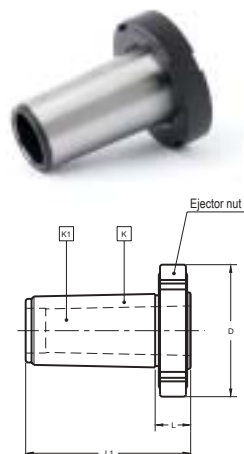
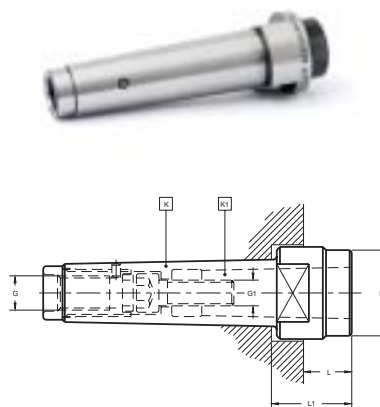

Fig.2



Maximum circular deviation between K and K₁ ≤ 0,008
Desviación circular máxima entre K y K₁ ≤ 0,008

FIG.	K	K ₁	LENGHT - LONGITUD L	L ₁	D	G	G ₁	COD.	Ejector nut Tuerca de extracción
1	M3	M1	17	60	46			003 01 01 04 20	001 99 13 01 50
1	M3	M2	17	60	46			003 01 01 04 30	001 99 13 01 50
1	M4	M1	18,5	70	56			003 01 01 05 20	001 99 13 01 60
1	M4	M3	18,5	70	56			003 01 01 05 40	001 99 13 01 60
1	M5	M1	22,5	106	68			003 01 01 06 20	001 99 13 01 75
1	M5	M2	22,5	106	68			003 01 01 06 30	001 99 13 01 75
1	M5	M3	22,5	106	68			003 01 01 06 40	001 99 13 01 75
1	M5	M4	22,5	106	68			003 01 01 06 50	001 99 13 01 75
2	M3	M1	25	37	25	M-12	M-6	003 01 02 04 20	
2	M4	M1	26,5	41,5	25	M-16	M-6	003 01 02 05 20	
2	M4	M2	26,5	41,5	32	M-16	M-10	003 01 02 05 30	
2	M5	M2	24,5	42,5	32	M-20	M-10	003 01 02 06 30	
2	M5	M3	24,5	42,5	40	M-20	M-12	003 01 02 06 40	

COD.

003 01 02 04 20
003 01 02 04 30

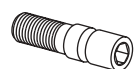

003 99 08 01 20
003 99 08 01 30

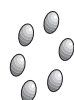

304 01 00 03 00
304 01 00 03 00



301 01 07 04 02
301 01 07 04 02



301 01 01 06 50
301 01 01 10 50
301 01 01 12 35



351 03 05 02 04
351 03 05 02 05
351 03 05 02 06

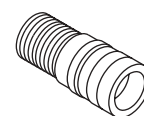

351 03 05 01 05
351 03 05 01 05
351 03 05 01 05



301 04 04 00 50
301 04 04 00 50
301 04 04 00 50

003 01 02 06 30
003 01 02 06 40

301 01 01 12 70
301 01 01 12 55

351 03 05 01 01
351 03 05 01 02

351 03 05 01 06
351 03 05 01 06

301 04 04 01 00
301 04 04 01 00

TYPE TIPO	TYPE TIPO	LENGTH LONGITUD
M2, M3, M4, M5, M6	M1 - M5	M

Alternative solutions
Soluciones alternativas 003 02 54 + 003 54 12 pgs. 7/8 and 9/6

For tapered Morse taper tools DIN 228-B
Para herramientas con lengüeta DIN 228-B

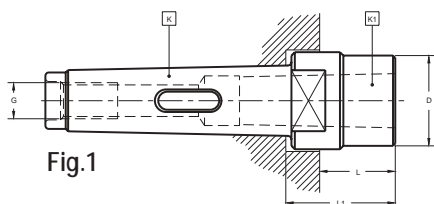

Fig.1

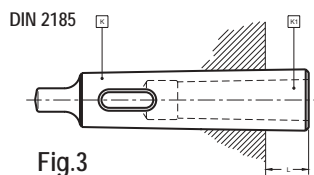

Fig.3

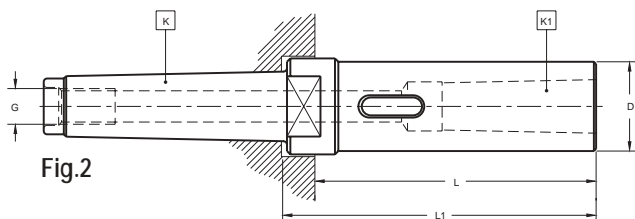

Fig.2

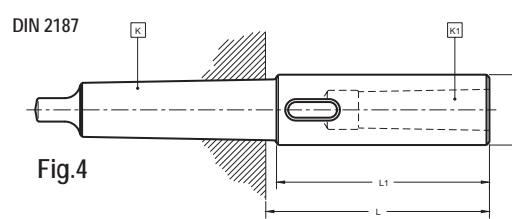

Fig.4

Maximum circular deviation between K and K₁ ≤ 0,008
Desviación circular máxima entre K y K₁ ≤ 0,008

Fig.	K	K ₁	LENGHT - LONGITUD		D	L ₁	G	COD.
			L	L				
1	M3	M1	17		25	29	M-12	003 01 11 04 20
1	M3	M2	32		32	44	M-12	003 01 11 04 30
1	M4	M1	23		25	38	M-16	003 01 11 05 20
2	M4	M2	150		32	165	M-16	003 01 11 05 33
1	M5	M2	23		32	41	M-20	003 01 11 06 30
2	M5	M2	135		32	153	M-20	003 01 11 06 33
2	M5	M3	150		40	165	M-20	030 01 11 06 43
2	M5	M4	190		48	208	M-20	030 01 11 06 53
3	M2	M1	17		—	—		003 02 11 03 20
4	M2	M1	85		20	76		003 02 11 03 23
4	M2	M2	100		30	91		003 02 11 03 33
3	M3	M1	5		—	—		003 02 11 04 20
4	M3	M1	81		20	76		003 02 11 04 23
3	M3	M2	18		—	—		003 02 11 04 30
4	M3	M3	121		36	112		003 02 11 04 43
3	M4	M1	6,5		—	—		003 02 11 05 20
3	M4	M2	6,5		—	—		003 02 11 05 30
3	M4	M3	22,5		—	—		003 02 11 05 40
4	M4	M4	148		48	137		003 02 11 05 53
3	M5	M3	6,5		—	—		003 02 11 06 40
4	M5	M3	118,5		36	112		003 02 11 06 43
3	M5	M4	21,5		—	—		003 02 11 06 50
4	M5	M5	185		63	172		003 02 11 06 63
3	M6	M3	8		—	—		003 02 11 07 40
3	M6	M4	8		—	—		003 02 11 07 50
3	M6	M5	8		—	—		003 02 11 07 60

TYPE TIPO	Ø	LENGTH LONGITUD
M4, M5, M6	46 - 90	M

Interchangeable with C.O. system
Intercambiable con el sistema C.O.

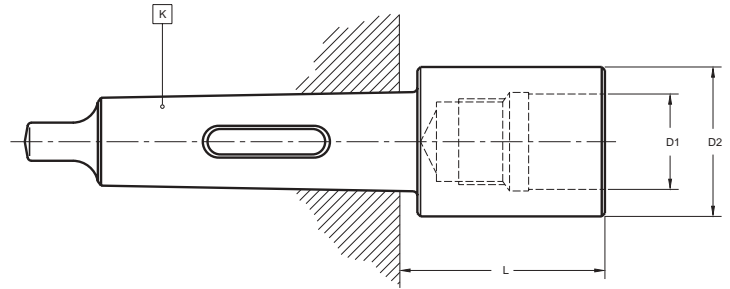

Maximum circular deviation between K and $D_1 \leq 0,005$
Desviación circular máxima entre K y $D_1 \leq 0,005$

K	D_1 H5	D_2	LENGHT - LONGITUD L	COD.
M4	30	46	66	003 02 54 05 06
M5	30	46	50	003 02 54 06 06
M5	46	63	90	003 02 54 06 07
M6	46	90	65	003 02 54 07 08

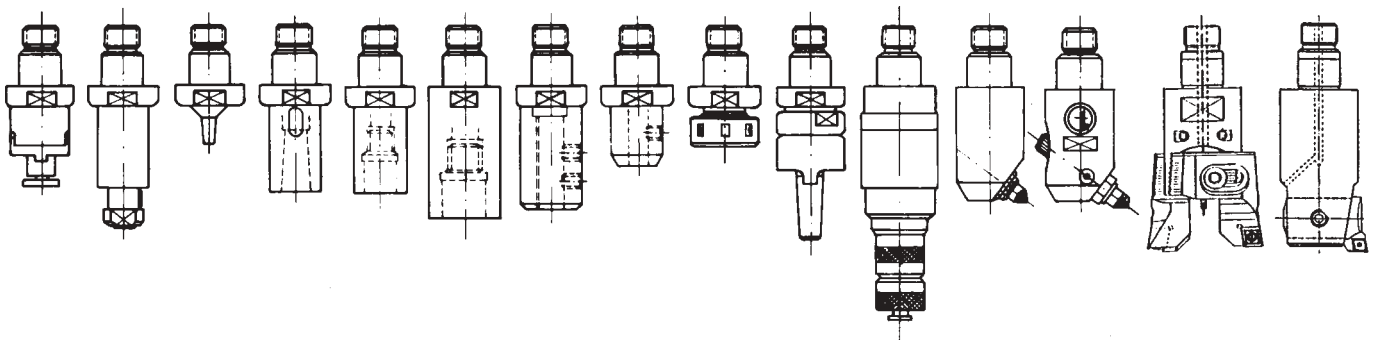
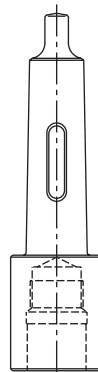

See pages 9/2 - Ver págs. 9/2

TYPE TIPO	Ø MAX	LENGTH - LONGITUD
M1, M3, M4, M5	16 - 32	M

For tools with cylindrical straight shank DIN 1835-A or threaded cylindrical shank DIN 1835-D
Para herramientas con mango cilíndrico liso DIN 1835-A o cilíndrico roscado DIN 1835-D

Alternative solution 004 01 06 pg. 7/10
Solución alternativa 004 02 06 pg. 7/10
003 02 54 + 004 54 06 pgs. 7/8 and 9/10



Fig.1

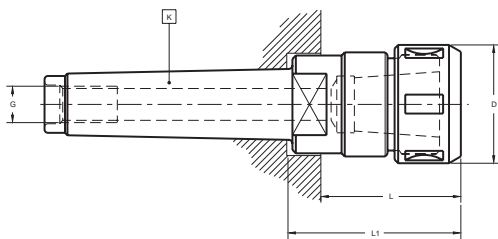
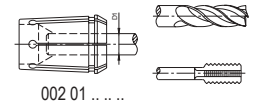
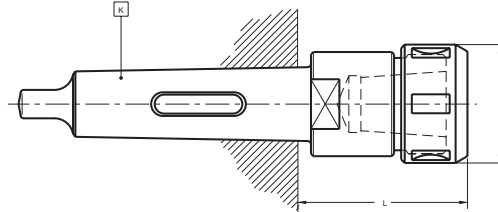
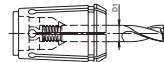

Fig.2



002 01 ...



002 03 ...

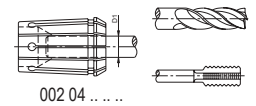

002 04 ...

Collets see pages 14/3 - 14/4
Pinzas ver págs 14/3 - 14/4

Maximum circular deviation between outer taper and collet housing $\leq 0,005$
Desviación circular máxima entre el cono exterior e interior $\leq 0,005$

FIG.	K	D ₁ máx.	LENGHT - LONGITUD L	L ₁	D	G	COD.
1	M3	25	78	90	60	M-12	004 01 01 04 05
1	M4	25	78	93	60	M-16	004 01 01 05 05
1	M5	25	52	70	60	M-20	004 01 01 06 05
1	M5	32	70	88	72	M-20	004 01 01 06 06
2	M3	25	75		60		004 02 01 04 05
2	M4	25	76		60		004 02 01 05 05
2	M5	25	70		60		004 02 01 06 05
2	M5	32	88		72		004 02 01 06 06

For boxes and composition or different sets, see pages 14/12.
Estuches y composición de diferentes juegos, ver págs 14/12.

Accessories, see pages 16/3 - 16/11
Accesorios ver págs 16/3 - 16/11

BALANCED NUT
TUERCA EQUILIBRADA

BEARING NUT
TUERCA GIRATORIA
(OPTIONAL)(OPCIONAL)

WRENCH (OPTIONAL)
LLAVE (OPCIONAL)

D₁ máx.

25 004 99 01 01 05
32 004 99 01 01 06

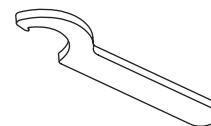

004 99 04 09 11
004 99 04 09 12

Collet chuks DIN 6499 (ER type) Portapinzas DIN 6499 (tipo ER)

TYPE TIPO	SIZE TAMAÑO	Ø MAX	LENGTH - LONGITUD
M1, M3, M4, M5	ER25 - ER40	16 - 32	M

For tools with cylindrical straight shank DIN 1835-A
Para herramientas con mango cilíndrico liso DIN 1835-A

Alternative solution Solución alternativa 004 01 01 pg. 7/9

Alternative solutions Soluciones alternativas 004 02 01 pg. 7/9
003 02 54 + 004 54 06 pgs. 7/8 and 9/10

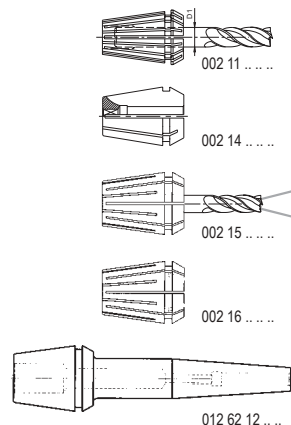
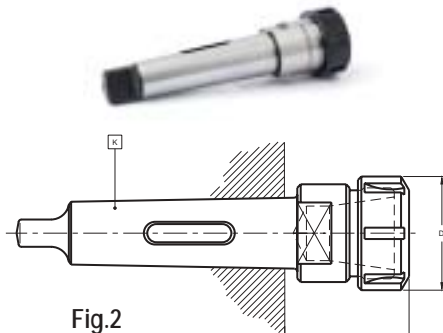
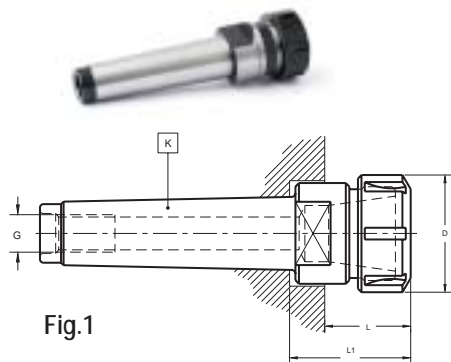

COLLETS see pages 14/5 - 14/7
PINZAS ver págs 14/5 - 14/7

Maximum circular deviation between K and $D_1 \leq 0,005$
Desviación circular máxima entre K y $D_1 \leq 0,005$

FIG.	K	TAMAÑO	D_1 máx.	LENGHT - LONGITUD		L_1	D	G	COD.
				L	L				
1	M2	(ER25)	16	—	55	42	M-10	004 01 06 03 05	
1	M3	(ER32)	20	58	70	50	M-12	004 01 06 04 06	
1	M4	(ER32)	20	55	70	50	M-16	004 01 06 05 06	
1	M4	(ER40)	26	75	90	63	M-16	004 01 06 05 07	
1	M5	(ER40)	26	52	70	63	M-20	004 01 06 06 07	
1	M5	(ER50)	34	72	90	78	M-20	004 01 06 06 08	
2	M2	(ER25)	16	55	—	42	—	004 02 06 03 05	
2	M3	(ER32)	20	62	—	50	—	004 02 06 04 06	
2	M3	(ER40)	26	68	—	63	—	004 02 06 04 07	
2	M4	(ER32)	20	64	—	50	—	004 02 06 05 06	
2	M4	(ER40)	26	70	—	63	—	004 02 06 05 07	
2	M5	(ER40)	26	70	—	63	—	004 02 06 06 07	
2	M5	(ER50)	34	90	—	78	—	004 02 06 06 08	

Accessories, see pages 16/3 - 16/11
Accesorios ver págs. 16/3 - 16/11

For boxes and composition of different sets see pages 14/13.
Estuches y composición de diferentes juegos, ver págs. 14/13.

BALANCED NUT
TUERCA EQUILIBRADA
(STANDARD - ESTÁNDAR)

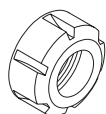

SIZE - TAMAÑO

ER 25	004 99 01 03 05
ER 32	004 99 01 03 06
ER 40	004 99 01 03 07
ER 50	004 99 01 03 08

BEARING NUT
TUERCA GIRATORIA
(OPTIONAL - OPCIONAL)



004 99 01 04 05
004 99 01 04 06
004 99 01 04 07
004 99 01 04 08

WRENCH
LLAVE
(OPTIONAL - OPCIONAL)

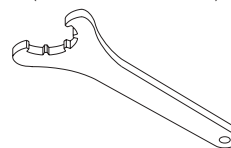

004 99 04 03 05
004 99 04 03 06
004 99 04 03 07
004 99 04 03 08

TYPE TIPO	TYPE TIPO	LENGTH LONGITUD
M2, M3, M4, M5	M3 - M33	M

Double axial compensation
Doble compensación axial

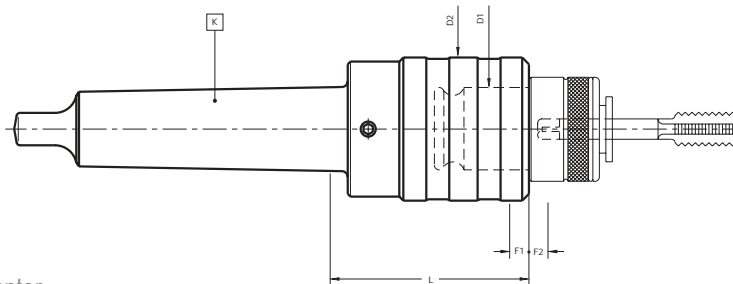

BILZ Adapter
Acoplamiento tipo BILZ

D	CAP.	D ₁	LENGHT - LONGITUD L	D ₂	F ₁	F ₂	COD.
M2	M3-M12 (M16)*	19	46	36	7,5	7,5	019 02 52 03 02
M3	M3-M12 (M16)*	19	46	36	7,5	7,5	019 02 52 04 02
M3	M8-M20 (M30)*	31	70	53	12,5	12,5	019 02 52 04 03
M4	M3-M12 (M16)*	19	46	36	7,5	7,5	019 02 52 05 02
M4	M8-M20 (M30)*	31	71	53	12,5	12,5	019 02 52 05 03
M4	M14-M33 (M48)*	48	104	78	20	20	019 02 52 05 04
M5	M14-M33 (M48)*	48	105	78	20	20	019 02 52 06 04

F₁ Compression run / Recorrido de compresión
F₂ Extension run / Recorrido de extensión

* With 002 22 ... and 002 24 ... adapters

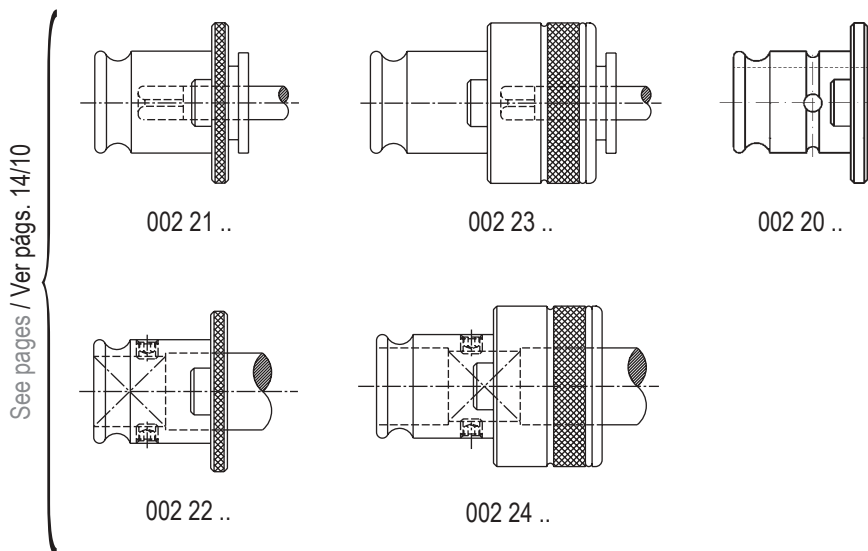

D ₁	002 21 02	002 22 02	002 23 02	002 24 02
19	002 21 02	002 22 02	002 23 02	002 24 02
31	002 21 03	002 22 03	002 23 03	002 24 03
48	002 21 04	002 22 04	002 23 04	002 24 04

Without
stopping the
machine

Sin parar la
máquina

Maximum rotation
speed: 2,000 rpm

Velocidad de giro
máxima: 2.000 rmp

Maximum
concentricity
achieved by taper
coupling

Manteniendo la
máxima
concentricidad
gracias a su
acoplamiento cónico



Just 10 mm
clearance
between
workpiece and
tool is enough

Siendo suficiente
el espacio de
solamente 10
mm. entre pieza
y herramienta

Equally effective
in vertical or
horizontal plain

Puede utilizarse
vertical u
horizontalmente

Rotation in either
direction

No influye el
sentido de giro

System not useful for milling



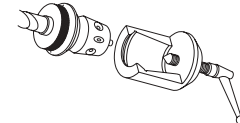
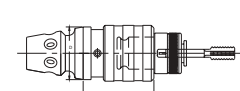
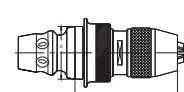
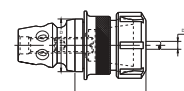
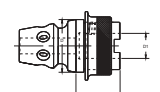
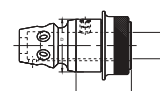
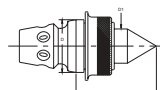
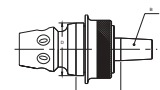
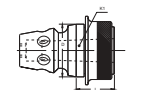
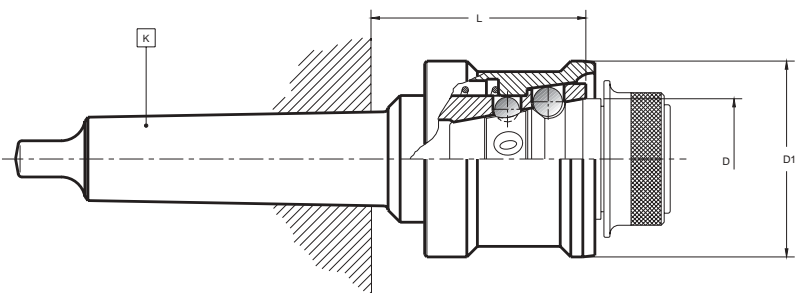

Sistema no válido para fresado

TYPE TIPO	Ø	LENGTH LONGITUD
M2, M3, M4, M5, M6	27,1 - 68,7	M

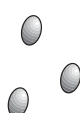

Maximum circular deviation between tapers $\leq 0,008$
Desviación circular máxima entre el cono exterior e interior $\leq 0,008$

K	D	LENGHT - LONGITUD		D ₁	COD.
		L			
M2	27,1	62		47	006 02 01 03 01
M2	40	77		63	006 02 01 03 02
M3	40	77		63	006 02 01 04 02
M4	40	78		63	006 02 01 05 02
M4	51,5	95		83	006 02 01 05 03
M5	51,5	95		83	006 02 01 06 03
M5	68,7	116		100	006 02 01 06 04
M6	68,7	112		100	006 02 01 07 04

COD.						
006 02 01 03 01	304 01 00 06 35	304 01 00 07 93	305 01 27 00 20	305 09 06 01 01	351 06 00 01 11	351 06 00 01 12
006 02 01 03 02	304 01 00 08 73	304 01 00 10 31	305 01 40 00 20	305 09 06 01 02	351 06 00 01 21	351 06 00 01 22
006 02 01 04 02	304 01 00 08 73	304 01 00 10 31	305 01 40 00 20	305 09 06 01 02	351 06 00 01 21	351 06 00 01 22
006 02 01 05 02	304 01 00 08 73	304 01 00 10 31	305 01 40 00 20	305 09 06 01 02	351 06 00 01 21	351 06 00 01 22
006 02 01 05 03	304 01 00 11 11	304 01 00 12 70	305 01 51 00 20	305 09 06 01 03	351 06 00 01 31	351 06 00 01 32
006 02 01 06 03	304 01 00 11 11	304 01 00 12 70	305 01 51 00 20	305 09 06 01 03	351 06 00 01 31	351 06 00 01 32
006 02 01 06 04	304 01 00 12 70	304 01 00 14 28	305 01 66 00 30	305 09 06 01 04	351 06 00 01 41	351 06 00 01 42
006 02 01 07 04	304 01 00 12 70	304 01 00 14 28	305 01 66 00 30	305 09 06 01 04	351 06 00 01 41	351 06 00 01 42

For more details see page 7/15 to 7/21
Para ampliar detalles ver págs. 7/15 a 7/21

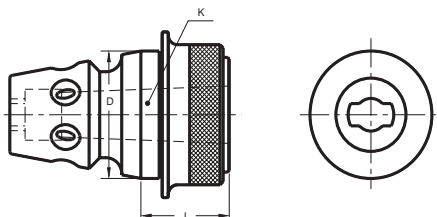

	D	27,1	40	51,5	68,7
MORSE TAPER ADAPTERS For tapered Morse taper tools <i>DIN 228-B</i> INTERIOR CONO MORSE Para herramientas con lengüeta FLOATING ADAPTERS - FLOTANTE	K ₁ Morse N°	1	1 2 3	1 2 3 4	1 2 3 4 5
	L	25	29 29 44	34 34 34 55	34 34 34 43 70
	COD. 006 99 01 □□□□	0102	0202 0203 0204	0302 0303 0304 0305	0402 0403 0404 0405 0406
	COD. 006 99 08 □□□□	-	- 0204	- 0304	- 0404
DRILL CHUCK ADAPTERS For DIN 238 or JACOBS ESPIGA DIN 238 Para mandrinos porta-brocas	B	B. 12	B. 12 B. 16	B. 16	B. 16 B. 18
	L	28	32 34	39	39 39
	COD. 006 99 02 □□□□	0101	0201 0202	0302	0402 0403
60° CENTERING POINT ADAPTERS PUNTO DE CENTRADO DE 60°	L	49	61	66	66
	D ₁	16	26	26	26
	COD. 006 99 03 □□□□	0101	0201	0301	0401
AUTOMOTIVE ADAPTERS For tools with shank DIN 6327 INTERIOR CILINDRICO Para herramientas con mango DIN 6327 (regulación axial)	D ₁	-	20	28	36
	L	-	42	45	45
	COD. 006 99 04 □□□□	-	0204	0306	0408
TAPPING ADAPTERS For "BILZ" tap adapters CON ALOJAMIENTO PARA ADAPTADORES PORTAMACHOS TIPO BILZ	D ₁	-	13 19	19 31	31 48
	CAP.	-	M1-M10 M3-M12	M3-M12 M8-M20	M8-M20 M14-M33
	L	-	29 29	41 41	41 54
	COD. 006 99 05 □□□□	-	0201 0202	0302 0303	0403 0404
COLLET ADAPTERS For DIN 6499 (ER) collets PORTA-PINZAS DIN 6499 (ER) para pinza 002 11 ...	D ₁	0,5 - 10	0,5 - 16	0,5 - 16	0,5 - 16
	L	50	60	63	63
	COD. 006 99 06 06 □□	13	25	35	45
SHORT DRILL CHUCK ADAPTERS PORTABROCAS INTEGRAL (CORTO)	D ₁	-	0 - 8	1 - 13	1 - 13 3 - 16
	L	-	82	98	98 95
	COD. 006 99 07 □□□□	-	2008	3113	4113 4316
TAPPING ADAPTERS To use with "BILZ" adapters PORTA-MACHOS CON COMPENSACIÓN AXIAL DE AMBOS SENTIDOS Para utilizar adaptadores tipo "BILZ"	D ₁	19	19 31	19 31	31 48
	CAP.	M3-M12	M3-M12 M8-M20	M3-M12 M8-M20	M8-M20 M14-M33
	L	45	45 69	45 69	69 110
	COD. 006 99 19 52 □□	12	22 23	32 33	43 44
EJECTOR DEVICE For tools set up on 006 99 01 and 006 99 08 EXPULSOR DE HERRAMIENTA Para las herramientas montadas en adaptadores 006 99 01 y 006 99 08	COD. 006 99 09 01 □□	01	02	03	04

Ø	TYPE TIPO	LENGTH LONGITUD
27,1 - 68,7	M1 - M5	M



For Morse taper DIN 228-B
Para Morse DIN 228-B

Maximum circular deviation between K and $D_1 \leq 0,008$
Desviación circular máxima entre K y $D_1 \leq 0,008$

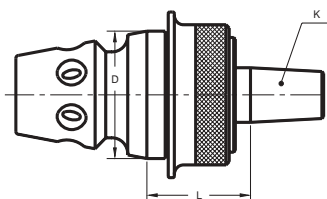

D	K	LENGHT - LONGITUD L	COD.		
27,1	M1	25	006 99 01 01 02	351 06 99 01 12	305 01 21 50 15
40	M1	29	006 99 01 02 02	351 06 99 01 22	305 01 34 00 20
40	M2	29	006 99 01 02 03	351 06 99 01 22	305 01 34 00 20
40	M3	44	006 99 01 02 04	351 06 99 01 22	305 01 34 00 20
51,5	M1	34	006 99 01 03 02	351 06 99 01 32	305 01 45 00 20
51,5	M2	34	006 99 01 03 03	351 06 99 01 32	305 01 45 00 20
51,5	M3	34	006 99 01 03 04	351 06 99 01 32	305 01 45 00 20
51,5	M4	55	006 99 01 03 05	351 06 99 01 32	305 01 45 00 20
68,7	M1	34	006 99 01 04 02	351 06 99 01 32	305 01 45 00 20
68,7	M2	34	006 99 01 04 03	351 06 99 01 32	305 01 45 00 20
68,7	M3	34	006 99 01 04 04	351 06 99 01 32	305 01 45 00 20
68,7	M4	43	006 99 01 04 05	351 06 99 01 32	305 01 45 00 20
68,7	M5	70	006 99 01 04 06	351 06 99 01 42	305 01 62 00 25

Ø	TYPE TIPO	LENGTH LONGITUD
27,1 - 68,7	B12 - B18	M



For DIN 238 or JACOBS
Para DIN 238 o JACOBS

Maximum circular deviation between tapers $\leq 0,008$
Desviación circular máxima entre conos $\leq 0,008$



D	K	LENGHT - LONGITUD L	COD.		
27,1	B-12	28	006 99 02 01 01	351 06 99 01 12	305 01 21 50 15
40	B-12	32	006 99 02 02 01	351 06 99 01 22	305 01 34 00 20
40	B-16	34	006 99 02 02 02	351 06 99 01 22	305 01 34 00 20
40	J-2	34	006 99 02 02 13	351 06 99 01 22	305 01 34 00 20
40	J-3	34	006 99 02 02 15	351 06 99 01 22	305 01 34 00 20
40	J-6	34	006 99 02 02 18	351 06 99 01 22	305 01 34 00 20
51,5	B-16	39	006 99 02 03 02	351 06 99 01 32	305 01 45 00 20
51,5	J-3	39	006 99 02 03 15	351 06 99 01 32	305 01 45 00 20
51,5	J-6	39	006 99 02 03 18	351 06 99 01 32	305 01 45 00 20
68,7	B-16	39	006 99 02 04 02	351 06 99 01 32	305 01 45 00 20
68,7	B-18	39	006 99 02 04 03	351 06 99 01 32	305 01 45 00 20

\emptyset	\emptyset	LENGTH	LONGITUD
27,1 - 68,7	16 - 26	M	

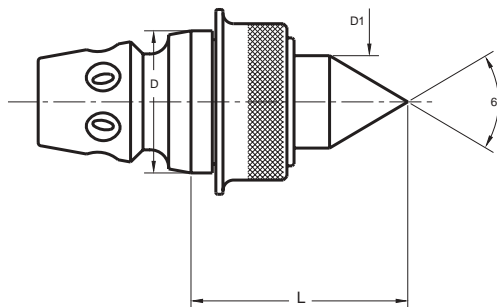
Punto de 60°



Maximum circular deviation between tapers $\leq 0,008$
Desviación circular máxima entre conos $\leq 0,008$



D	D ₁	LENGHT - LONGITUD L	COD.		
27,1	16	49	006 99 03 01 01	351 06 99 01 12	305 01 21 50 15
40	26	61	006 99 03 02 01	351 06 99 01 22	305 01 34 00 20
51,5	26	66	006 99 03 03 01	351 06 99 01 32	305 01 45 00 20
68,7	26	66	006 99 03 04 01	351 06 99 01 32	305 01 45 00 20

\emptyset	\emptyset	LENGTH	LONGITUD
40 - 68,7	20 - 36	M	

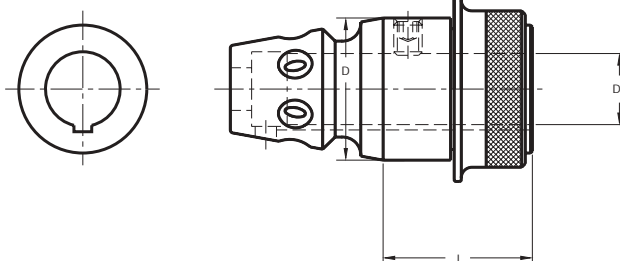
For tools with DIN 6327 shanks
Para herramientas con mango DIN 6327



Maximum circular deviation between outer taper and hole $D_1 \leq 0,008$
Desviación circular máxima entre el cono exterior y $D_1 \leq 0,008$



D	D ₁	LENGHT - LONGITUD L	COD.			
40	20	42	006 99 04 02 04	301 01 03 08 10	351 06 99 01 22	305 01 34 00 20
51,5	28	45	006 99 04 03 06	301 01 03 08 12	351 06 99 01 32	305 01 45 00 20
68,7	36	45	006 99 04 04 08	301 01 03 08 16	351 06 99 01 32	305 01 45 00 20

Ø	TYPE TIPO	LENGTH LONGITUD
27,1 - 68,7	M1 - M33	M

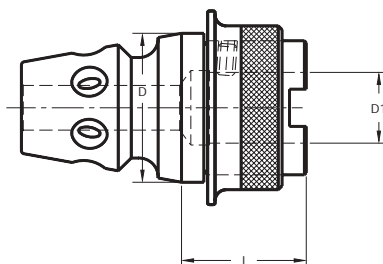
For "BILZ" type tap adapters
Para adaptadores tipo "BILZ"



BILZ Adapter
Acoplamiento tipo BILZ

D	CAP.	D ₁	LENGHT - LONGITUD L	COD.			
27,1	M1-M10	13	29	006 99 05 01 01	301 01 03 05 10	351 06 99 01 12	305 01 21 50 15
40	M1-M10	13	29	006 99 05 02 01	301 01 03 05 10	351 06 99 01 22	305 01 34 00 20
40	M3-M12 (M16)*	19	29	006 99 05 02 02	301 01 03 05 08	351 06 99 01 22	305 01 34 00 20
51,5	M1-M10	13	41	006 99 05 03 01	301 01 03 05 10	351 06 99 01 32	305 01 45 00 20
51,5	M3-M12 (M16)*	19	41	006 99 05 03 02	301 01 03 06 12	351 06 99 01 32	305 01 45 00 20
51,5	M8-M20 (M30)*	31	41	006 99 05 03 03	301 01 03 06 08	351 06 99 01 32	305 01 45 00 20
68,7	M8-M20 (M30)*	31	41	006 99 05 04 03	301 01 03 06 08	351 06 99 01 32	305 01 45 00 20
68,7	M14-M33 (M48)*	48	54	006 99 05 04 04	301 01 03 08 08	351 06 99 01 42	305 01 62 00 25

F₁ Compression run
F₂ Extension run

F₁ Recorrido de compresión
F₂ Recorrido de extensión

* With 002 22 ... and 002 24 ... adapters

* Con adaptadores 002 22 ... y 002 24 ...

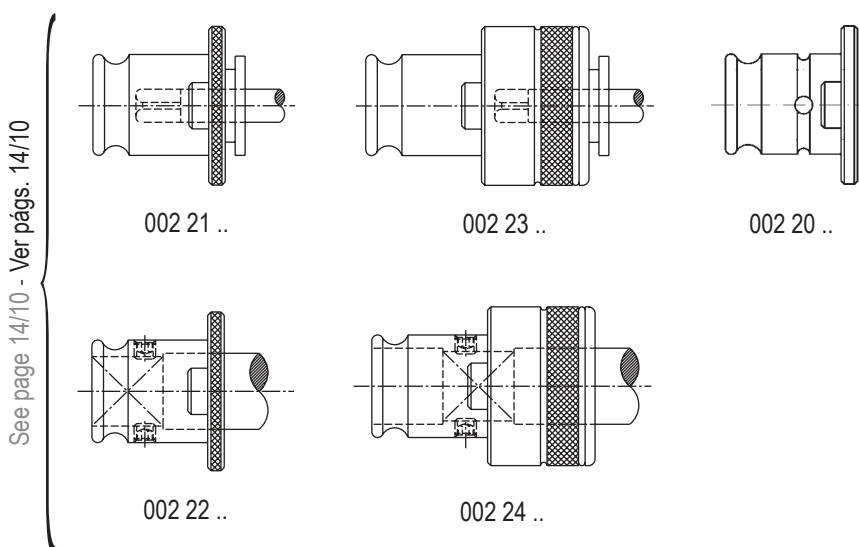



D ₁	002 21 ..	002 22 ..	002 23 ..	002 24 ..
19	002 21 02	002 22 02	002 23 02	002 24 02
31	002 21 03	002 22 03	002 23 03	002 24 03
48	002 21 04	002 22 04	002 23 04	002 24 04

Ø	TYPE TIPO	LENGTH LONGITUD
27,1 - 68,7	ER16 - ER25	M

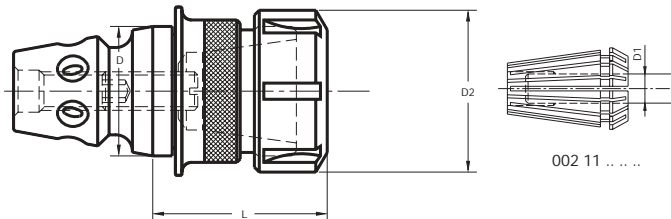



For collets DIN 6499 (ER type)
Para pinzas DIN 6499 (tipo ER)



Maximum circular deviation between tapers $\leq 0,008$
Desviación circular máxima entre conos $\leq 0,008$

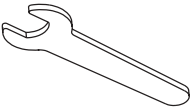

D	SIZE TAMAÑO	D ₁ máx.	D ₂	LENGHT - LONGITUD L	COD.	COLLETS PINZAS			
27,1	(ER16)	10	28	50	006 99 06 06 13	002 11 03 ...	301 99 02 12 01	351 06 99 01 12	305 01 21 50 15
40	(ER16)	10	28	56	006 99 06 06 23	002 11 03 ...	301 99 02 12 01	351 06 99 01 22	305 01 34 00 20
40	(ER25)	16	42	60	006 99 06 06 25	002 11 05 ...	301 99 02 16 01	351 06 99 01 22	305 01 34 00 20
51,5	(ER25)	16	42	63	006 99 06 06 35	002 11 05 ...	301 99 02 16 01	351 06 99 01 32	305 01 45 00 20
68,7	(ER25)	16	42	63	006 99 06 06 45	002 11 05 ...	301 99 02 16 01	351 06 99 01 32	305 01 45 00 20

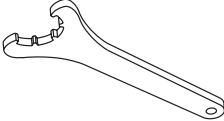
Accessories, see pages 14/5 - 14/7
Accesorios ver págs. 14/5 - 14/7

SIZE TAMAÑO	BALANCED NUT (STANDARD) TUERCA EQUILIBRADA (ESTÁNDAR)	BEARING NUT (OPTIONAL) TUERCA GIRATORIA (OPCIONAL)	WRENCH (OPTIONAL) LLAVE (OPCIONAL)
ER 16	 004 99 01 08 03	 004 99 01 04 03	 004 99 04 06 25
ER 25	 - 004 99 01 03 05	 - 004 99 01 04 05	 - 004 99 04 03 05

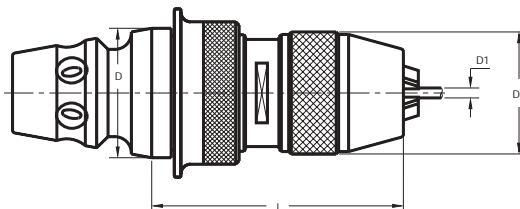
\emptyset	\emptyset	LENGTH	LONGITUD
40 - 68,7	0 - 16	M	



D	D ₁	LENGHT - LONGITUD L	D ₂	COD.		
40	0-8	82	36	006 99 07 20 08	351 06 99 01 22	305 01 34 00 20
51,5	1-13	89	48	006 99 07 31 13	351 06 99 01 32	305 01 45 00 20
68,7	1-13	98	48	006 99 07 41 13	351 06 99 01 32	305 01 45 00 20
68,7	3-16	95	54	006 99 07 43 16	351 06 99 01 42	305 01 62 00 25

D₁

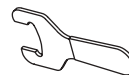



0-8	351 02 60 00 08	351 02 61 00 08	020 99 03 00 08
1-13	351 02 60 01 13	351 02 61 01 13	020 99 03 01 13
3-16	351 02 60 03 16	351 02 61 03 16	020 99 03 03 16

Ø	TYPE TIPO	LENGTH LONGITUD
40 - 68,7	M3	M

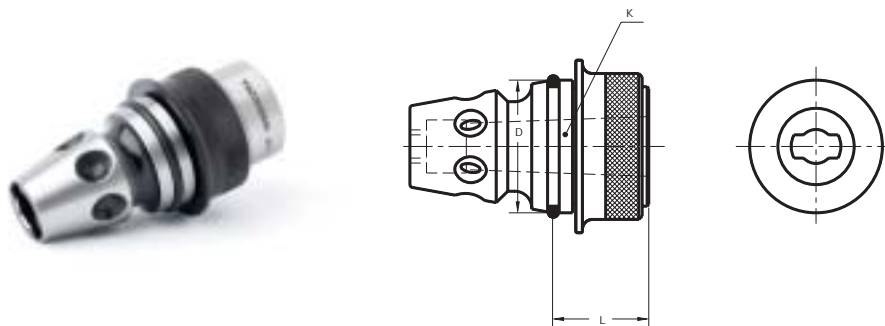
For Morse taper DIN 228-B
Para Morse DIN 228-B



D	K	LENGHT - LONGITUD L	COD.			
40	M3	44	006 99 08 02 04	305 04 03 53 20	351 06 99 01 22	305 01 34 00 20
51,5	M3	34	006 99 08 03 04	305 04 04 42 30	351 06 99 01 32	305 01 45 00 20
68,7	M3	34	006 99 08 04 04	305 04 06 43 00	351 06 99 01 32	305 01 45 00 20

Ø	LENGTH LONGITUD
27,1 - 68,7	M

For tool set up in 006 99 01 and 006 99 08
Para extracción de herramienta en 006 99 01 y 006 99 08

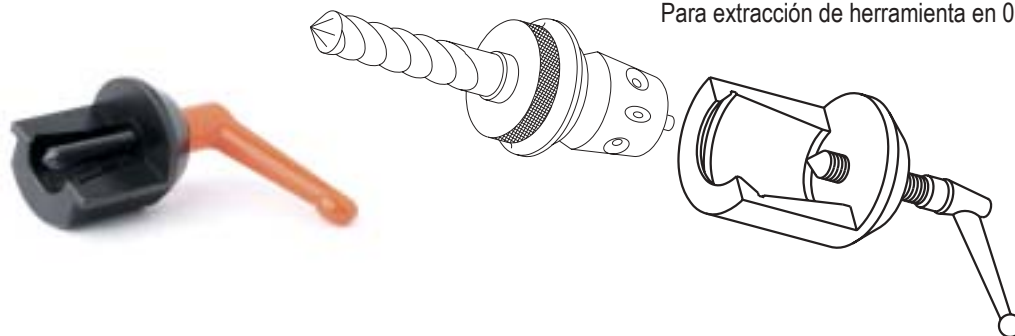

D	COD.
27,1	006 99 09 01 01
40	006 99 09 01 02
51,5	006 99 09 01 03
68,7	006 99 09 01 04

Tapping adapter Adaptador para portamachos

Ø	TYPE TIPO	LENGTH LONGITUD
27,1 - 68,7	M3 - M33	M

Double axial compensation
Doble compensación axial

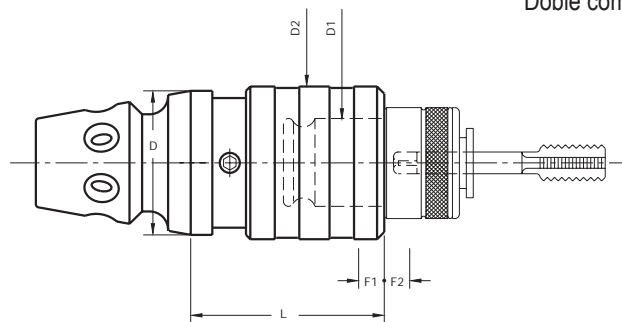

BILZ Adapter
Acoplamiento tipo BILZ

D	CAP.	D ₁	LENGHT - LONGITUD L	D ₂	F ₁	F ₂	COD.
27,1	M3-M12 (M16)*	19	45	36	7,5	7,5	006 99 19 52 12
40	M3-M12 (M16)*	19	45	36	7,5	7,5	006 99 19 52 22
40	M8-M20 (M30)*	31	69	53	12,5	12,5	006 99 19 52 23
51,5	M3-M12 (M16)*	19	46	36	7,5	7,5	006 99 19 52 32
51,5	M8-M20 (M30)*	31	69	53	12,5	12,5	006 99 19 52 33
68,7	M8-M20 (M30)*	31	69	53	12,5	12,5	006 99 19 52 43
68,7	M14-M33 (M48)*	48	110	78	20	20	006 99 19 52 44

F₁ Compression run / Recorrido de compresión
F₂ Extension run / Recorrido de extensión

* With 002 22 ... and 002 24 ... adapters

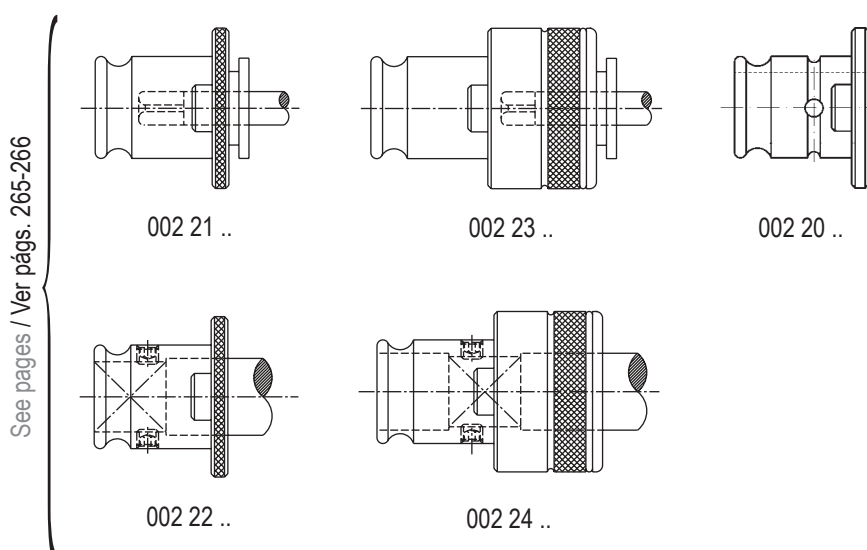

D ₁				
19	002 21 02	002 22 02	002 23 02	002 24 02
31	002 21 03	002 22 03	002 23 03	002 24 03
48	002 21 04	002 22 04	002 23 04	002 24 04